

MANUFACTURER:



DRAWN BY:

CHECKED BY:

PRODUCT TITLE:

REINFORCED CONCRETE PIPE

D1500 X 2500MM

PAGE

1

PRODUCT DATA SHEET

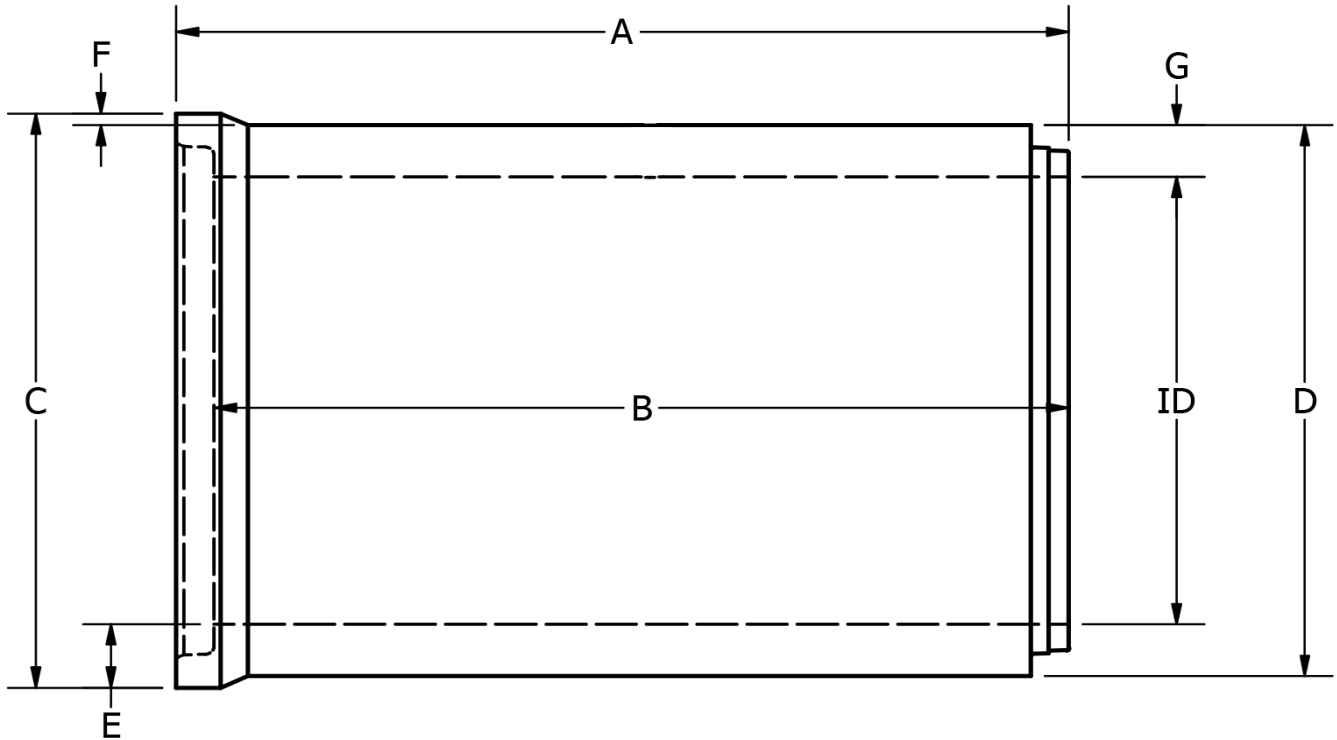

ID	A	B	C	D	E	F	G	WALL TYPE	D-LOAD CLASS	STEEL (MPa)		WEIGHT (Kg)
										INNER	OUTER	
1500	2630	2500	1920	1800	210	60	150	C	II	235	235	5080
1500	2630	2500	1920	1800	210	60	150	C	III	500	500	5080
1500	2630	2500	1920	1800	210	60	150	C	IV	500	500	5080

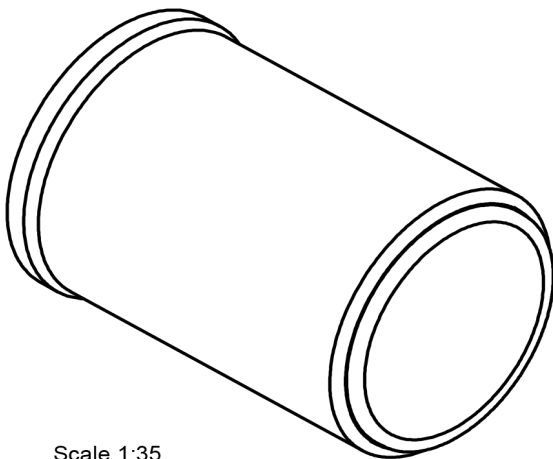

Scale 1:35

ISOMETRICS VIEW

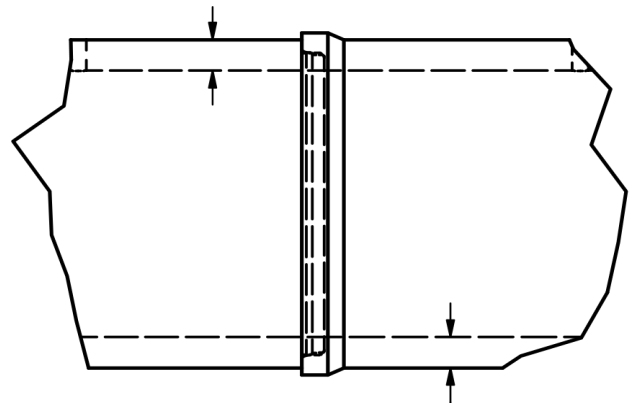

Scale 1:35

JOINTS VIEW

NOTES:

1. ALL DIMENSIONS SUBJECT TO ALLOWABLE SPECIFICATION TOLERANCES AND PARAMETERS
2. MATERIALS
 - 2.1 CONCRETE FOR ALL RC PIPE SHALL BE CUBE STRENGTH TEST WITH CHARACTERISTIC STRENGTH IN MPa AT 28 DAYS
 - 2.2 REBARS
 - YIELD STRENGTH IN MPa
 - TENSILE STRENGTH IN MPa
3. PIPE IS MANUFACTURED PER EUROPEAN STANDARD, AND CONFORMS/OR TO MEET ASTM C-76
4. CONCRETE STRENGTH IS 32MPa @ 28 DAYS